

Infrastructure – Water Proofing Stage

WATER STOPS (PVC, SWELLABLE & INJECTION)

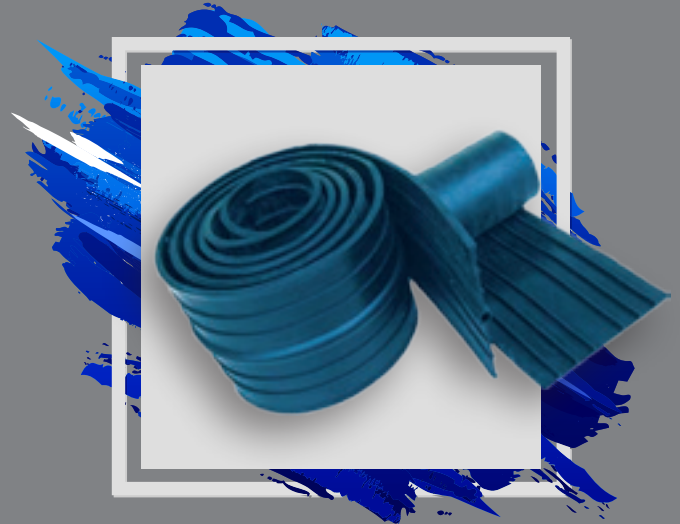

COMPOSITION AND MATERIALS

UNIPRO WaterStop is a specially formulated Polyvinyl Chloride (PVC) compound. Flexible, resilient, tough, chemically inert, is not affected by weathering, low temperatures, or constant immersion in water. It will withstand rough treatment during installation, yet is relatively easy to install and splice. Unitech WaterStop is unaffected by concrete additives and most water solutions of organic chemicals. It has the ability to accommodate joint movements and at the same time prevent water passage through the joints.

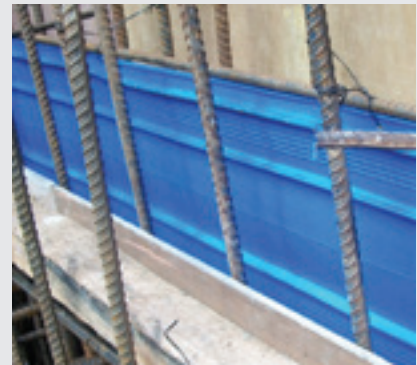

USAGE

UNIPRO WaterStop is designed for use in any concrete structure which contains joints and is subjected to a hydrostatic load on one face of the structure. It prevents water movement through concrete joints in water reservoirs, canals, dams, sewage treatment plants, bridges, stadiums, basements, floor slabs, parking garages, and similar structures.

PROPERTIES

UNITECH WaterStop is unaffected by alkalis, acids, hydrocarbons, oxidation, sewerage, and most water solutions of organic chemicals. It is extremely resistant to abrasion, corrosion, and aging. For physical properties see Table 1.

AREAS OF APPLICATION

STRUCTURAL ENGINEERING

- Bridges
- Industrial buildings
- Power stations

WATER EXCLUDING

- Basement areas
- Underground car parks
- Tunnels
- Retaining walls
- Suspended slabs
- Pits
- Roof slabs

WATER RETAINING

- Sewage treatment plants
- Water treatment plants
- Swimming pools
- Reservoirs
- Dams and Spillways
- Bund walls



PVC WATER STOP

PHYSICAL PROPERTIES

| PROPERTIES | TEST METHOD | NOMINAL VALUES |
|---------------------------------|--------------------------|---|
| Specific Gravity | ASTM D 792 | 1.4±0.1 g/cc |
| Tensile Strength | ASTM D 638 DIN 53455 | 13.7±1 MPa 13.7 N/mm ² |
| Ultimate Elongation | ASTM D 638 DIN 53455 | 300% 300% |
| Hardness-Shore - A | ASTM D 2240 DIN 53505 | 75±5 75±5 |
| Stiffness in Flexure | ASTM D 747 | 4.14 MPa 4.14 N/mm ² |
| Tear Resistance | ASTM D 624 | 285 lb/in.min 50KN/m |
| Water Absorption | | |
| - 24 hours | ASTM 570 | 0.82% |
| - 48 hours | ASTM 570 | 0.320% |
| Resistance to Chemicals Density | ASTM 570 | Excellent to inorganic solutions: salts, hydrocarbons, acids, and alkalis |

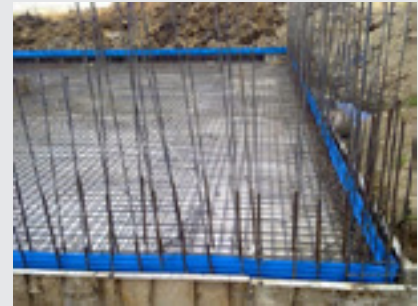

INSTALLATION OF THE WATERSTOPS

The waterstop is to be installed together with the reinforcement and attached to the same. Auxiliary aids:

- a- Waterstops clips and binding wire with a spacing of approximately 30 cm.
- b- Factory-installed brass lugs and binding wire.

Stabilized construction joint waterstops with round steel embedded in the waterstop every 10 cm or external round steel clips at about the same spacing offer significant advantages during installation. The latter make the use of waterstop clips superfluous. External waterstops are to be placed on the sub-base or to be fixed on the formwork before the rebars are installed.

CAUTION

Despite careful storage, attention shall be paid to the waterstops being free from any soiling during installation. During installation, there is a risk of the waterstops being damaged by contact with sharp edges of the rebars.

Before placing the concrete, the waterstops shall be checked once again for cleanliness and proper installation, i.e.

- The absence of any dirt (e.g. concrete remainders, sawdust, crown caps and other foreign objects),
- Secure fastening,
- Alignment with respect to the joint, and
- Distance from the rebars.

It is advisable to fix the waterstop in place with a preliminary layer of concrete. During compaction, the vibrating head shall not come into contact with the waterstop.

When removing the formwork it is of prime importance that the waterstop is neither damaged nor loosened or detached from the fresh concrete.

This is especially important for external waterstops. If in spite of all cautionary measures - the waterstop is still found to be defective areas shall be marked and immediately repaired in an appropriate way.

External waterstops shall be secured in place before backfilling the working space. During prolonged interruptions of the construction work, the waterstops shall be protected against any external influence.

This protection can be achieved by covering up the waterstops with a formwork box.

PVC WATER STOP

TYPES OF WATERSTOPS

Two main types of profiles are available. Unitech Centerstop for centrally placed applications and Unitech Outerstop for externally placed applications. These profiles are available in rolls with separate intersections supplied to simplify and minimise on-site fabrication.

1- Center ribbed type with center bulb:

Center ribbed type with center bulb waterstop profiles are fixed generally on the middle of the slab or wall joint of the concrete structure. This profile provides a barrier to water trying either to enter or leave the structure. The central bulb enables it to be used in joints where movement may occur. It can be used in horizontal and vertical applications for expansion, construction joints. The bulb works with both lateral and transverse movement, and the ribs provide better water tight sealing than do non-ribbed types.

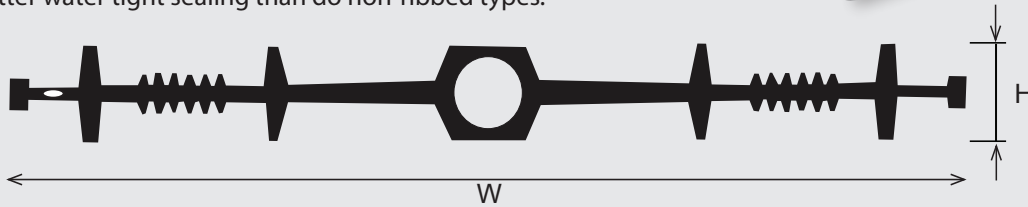
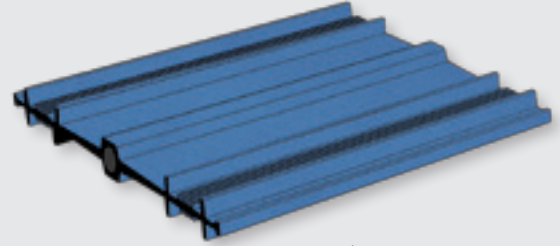

2- Center Ribbed type without center bulb :

This type is designed for horizontal and vertical construction joints where an economical and easy to install product is required.

IC-xxx type

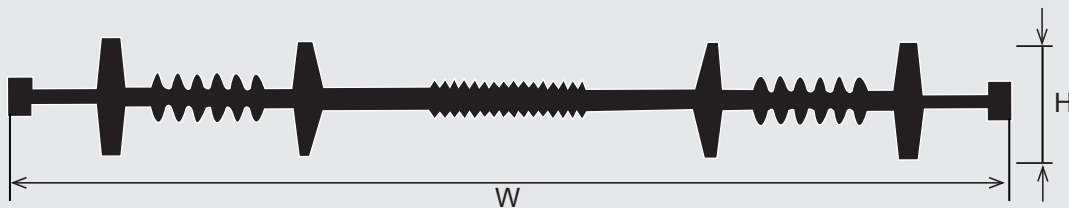
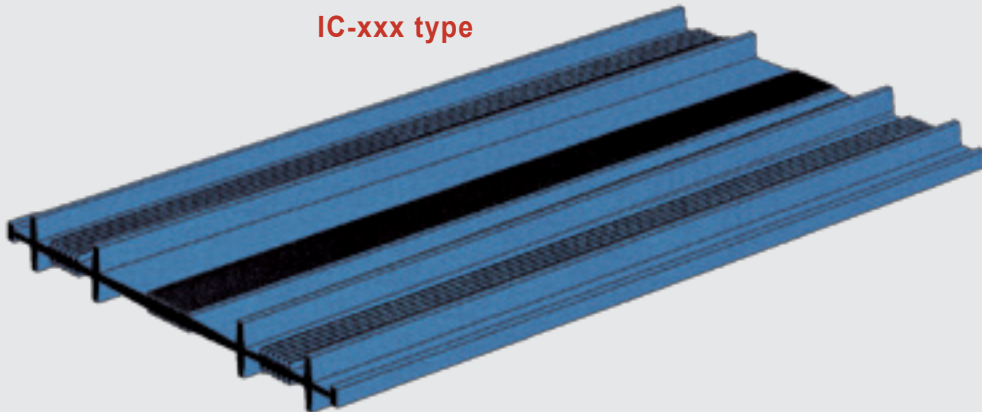

PVC WATER STOP

TYPES OF WATERSTOPS

Two main types of profiles are available. Unitech Centerstop for centrally placed applications and UNIPRO Outerstop for externally placed applications. These profiles are available in rolls with separate intersections supplied to simplify and minimise on-site fabrication.

OUTERSTOP PROFILES

Externally placed profiles are designed for use in floor and basement areas in horizontal and vertical joints. UBI Outerstop profiles are located on the external face to the concrete. The specially designed keys enable compaction to be obtained around the waterstop, bonding the concrete and waterstop together forming a positive water barrier.

1- Outer Ribbed type with v-bulb :

For use in expansion, construction and contraction joints, the flat top bulb section allows support for any joint filler and allows for any movement in the structure. The bottom of the bulb has a "V" shaped notch so that should the joint open beyond the capacity of the PVC bulb, the bottom of it will tear along the notch and permit the bulb to open whilst still maintaining the water barrier.

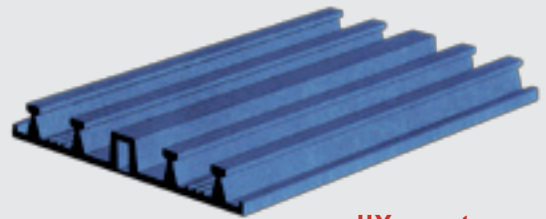

IIX-xxx type

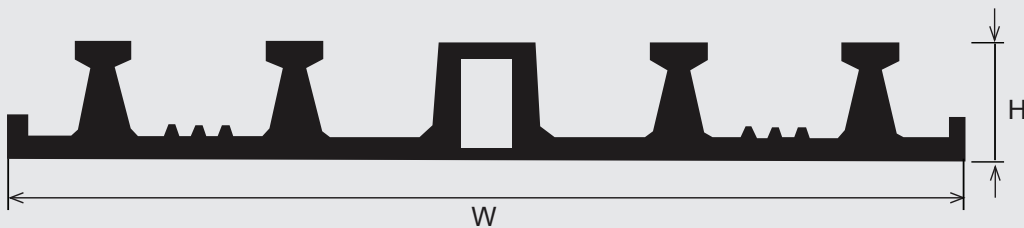

2- Outer Ribbed type without V-bulb:

It is important that all waterstops are held securely during the concrete pour and that the concrete is properly compacted to remove voids and porous areas. For horizontal applications where an already stable support exists, UNITECH outerstop profiles generally require no fixing as they are laid centrally along the joint being formed. For use in construction and contraction joints, where no movement is expected

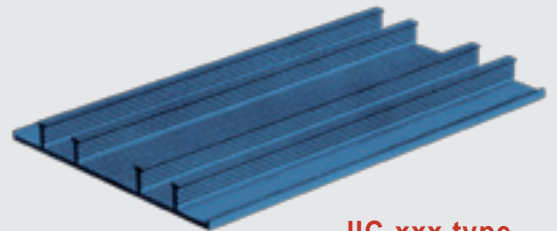

IIC-xxx type



PVC WATER STOP

INTERSECTIONS

A range of prefabricated intersections, both standard and specials are available for each UBI profile.

These are factory made and are usually very difficult to make in the field. By using factory-made intersections, the contractor has to only make straight joining welds on site.

The standard leg length is 250mm. Factory welded units to suit lift pits, etc. are also available.

Intersection pieces

A range of intersection pieces is available for each profile. The standard leg is 250mm.

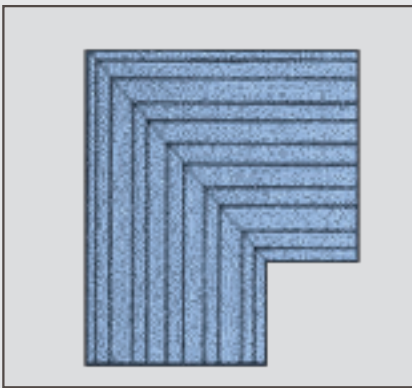

Two way flat

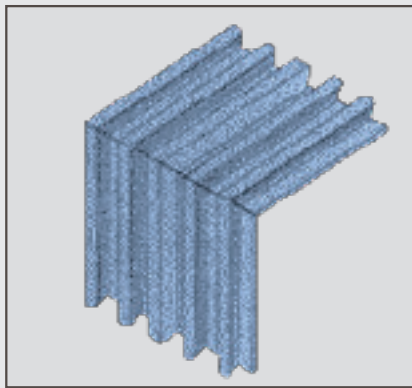

Two way vertical outside profile

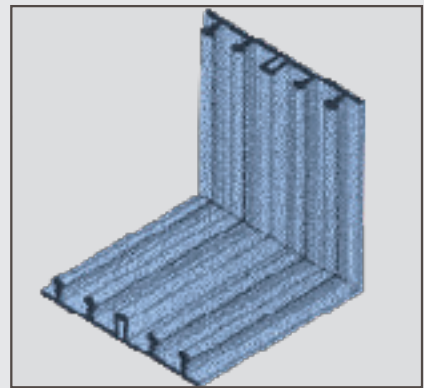

Two way vertical inside profile

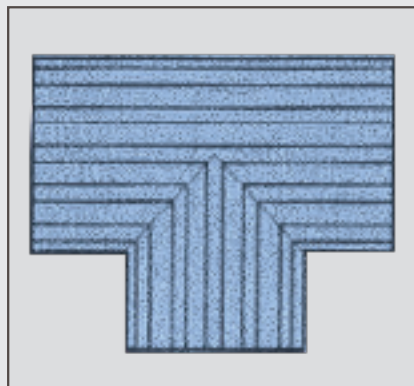

Three way flat

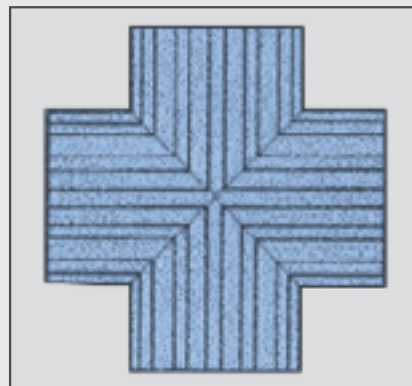

Four way flat

PVC WATER STOP

WELDING EQUIPMENT

Following is the procedure, for field splicing PVC waterstops. On-site welding is a relatively simple exercise using heat welding equipment comprising of an adjustable welding jig and heating blade.

- 1- The number of joins in the waterstop shall be the minimum practical. Straight splices maybe carried out in the field but all intersections should be factory produced.
- 2- Preheat welding blade.
- 3- Place the ends of the waterstop through the adjustable jig and clamp down using assembly screws, cut both ends off square with a sharp knife or fine tooth saw. (Refer fig.1)
- 4- Loosen the clamps and slide back allowing approximately 10-15mm of waterstop to protrude from both ends, then clamp the jigs tightly in position. At this stage when the jig slides together the ends should meet squarely and the profiles are to match up. If the waterstop is not square to each other or the profiles do not meet up, loosen the clamps on the jig and Adjust the waterstop until ends meet up perfectly, tighten up the clamps ready for welding. (Refer Fig. 2)
- 5- Slide the two halves of the jig apart and position the preheated welding blade on the bars between the waterstop

- profiles. Slide the two sections back together until they press against the sides of the heating blade and maintain pressure against the blade in this position until a bead of molten PVC approximately 3mm thick appears along the length of the blade. The PVC should melt without charring or burning. (Refer Fig. 3)
 - 6- Slide the jig apart, remove the heating blade vertically and then slide the two halves of the profile back together holding under pressure for approximately 1 minute allowing the molten PVC to fuse together. (Refer Fig. 3)
 - 7- Unclamp the jigs and carefully remove the joined waterstop taking care not to flex joint until it is cool.
- Welding should only be carried out in areas with adequate ventilation, if welding in confined locations, it is considered necessary to provide forced ventilation or a suitable respirator. Care shall be taken not to heat the PVC to the point of charring as harmful fumes may be released.

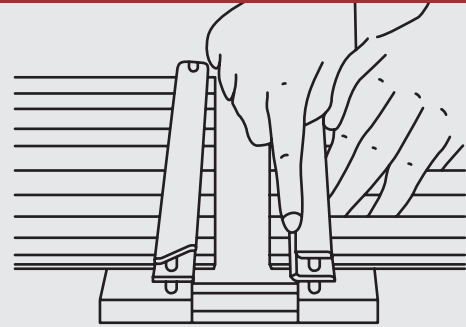

Fig.1

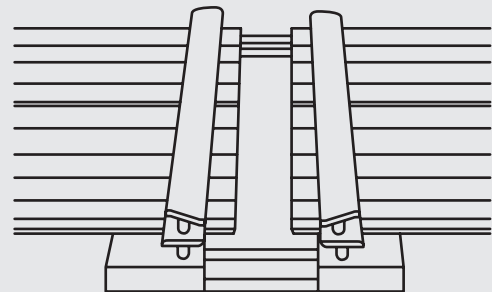

Fig.2

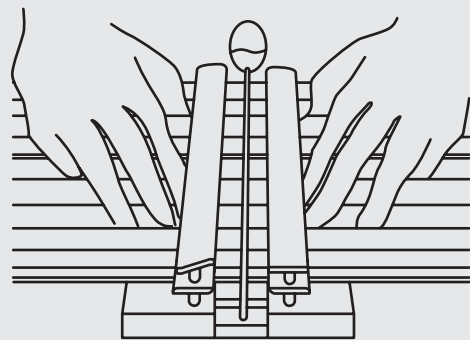

Fig.3

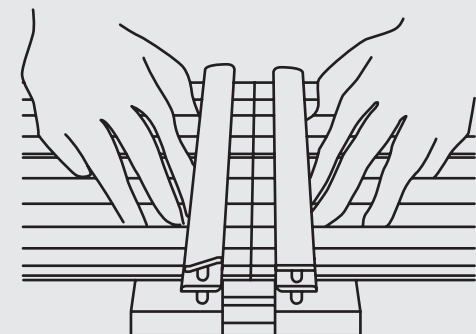

Fig.4

LOCATION

Salwa Road - Al Waab City - C2 Building - 2Nd Floor - Office 203 - Above Audi Showroom
Tel: +974 4451 3301/3302/3303 - Fax: +974 4451 3305 - P.o.box: 23910 Doha-Qatar

